

81008

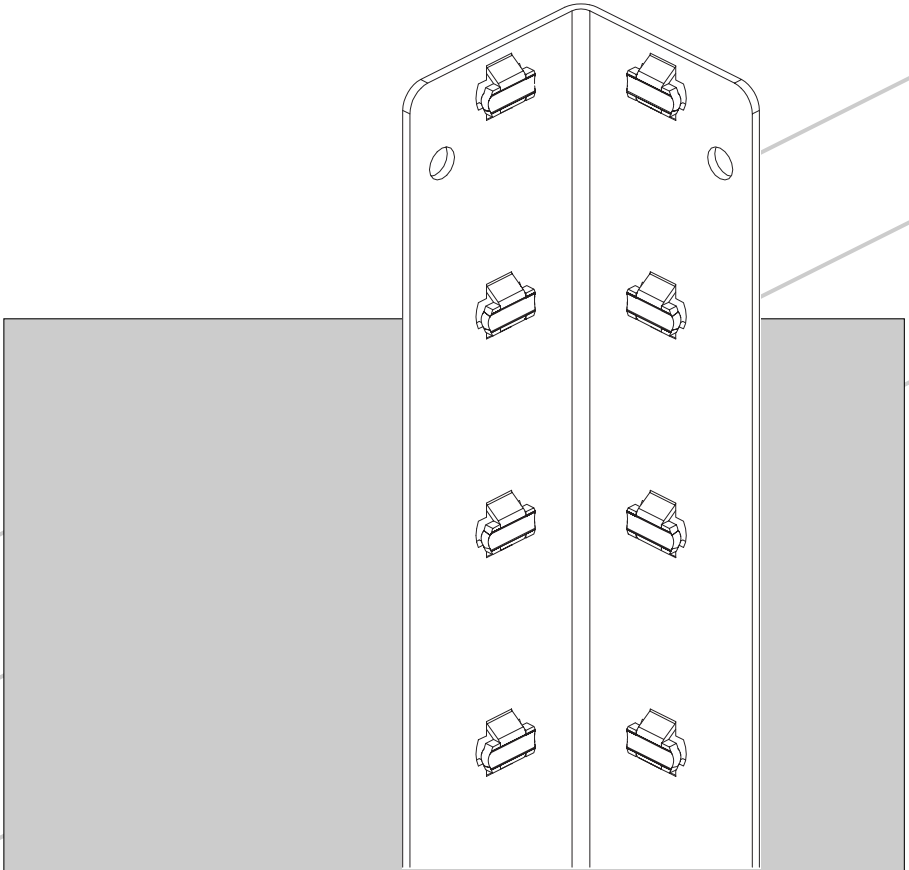

Das Lagersystem

SPEED - RACK



Stand 06.02.2006

AUFBAU- und BEDIENUNGSANLEITUNG

assembling and service instructions
instructions de montage et du service

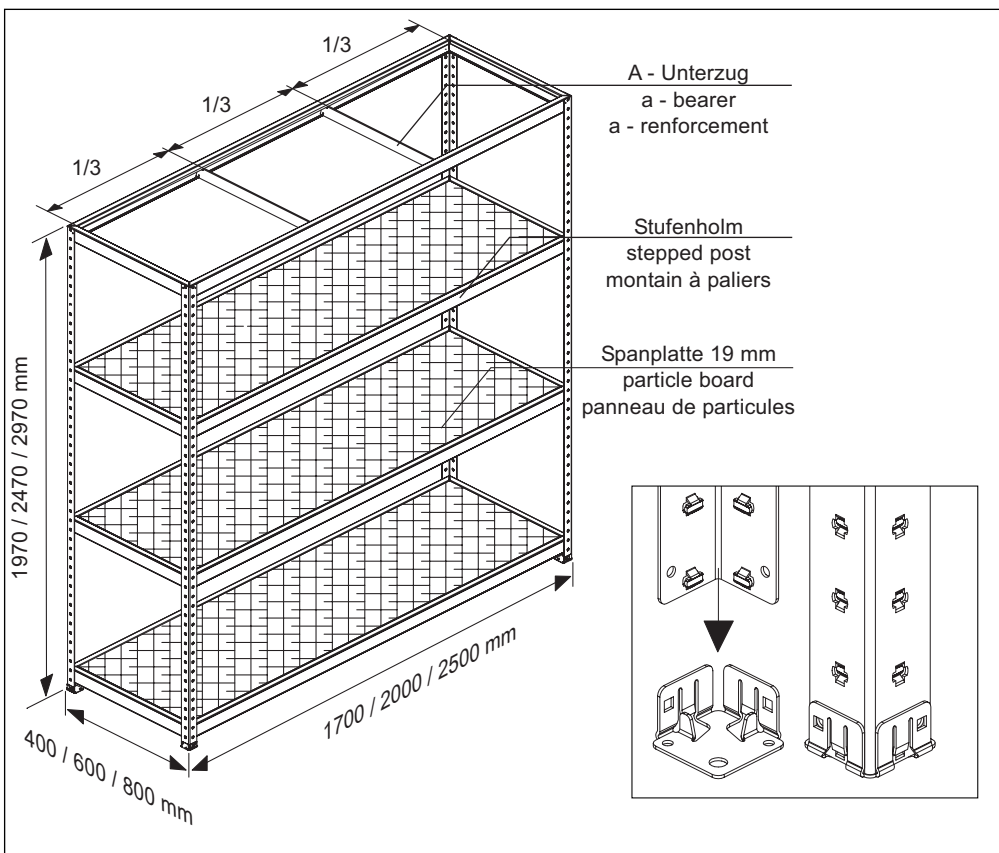

Bodenebenenheiten mit Ausgleichsblechen ausgleichen.

Level out unevenness with the help of base plates.

Egalisez des inégalités à l'aide de sémelles.

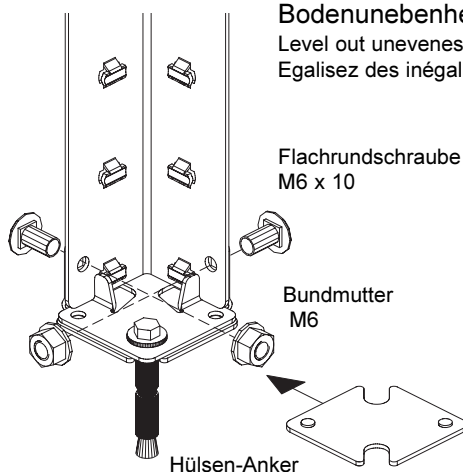

Aus Sicherheitsgründen müssen Regale mit einem Höhen - Tiefen Verhältnis größer 5:1 gegen Kippen gesichert werden.

For safety reasons, it is essential to anchor shelf units with a height-to-depth ratio of higher 5:1 to prevent them against toppling over.

Pour des raisons de sécurité, les rayons dont le rapport hauteur-profondeur est >5:1 doivent être sécurisés contre un basculement.

Benötigtes Werkzeug :
needed tools :
les utiles indispensables :

Gummihammer
rubberhammer
marteau ou en caoutchouc

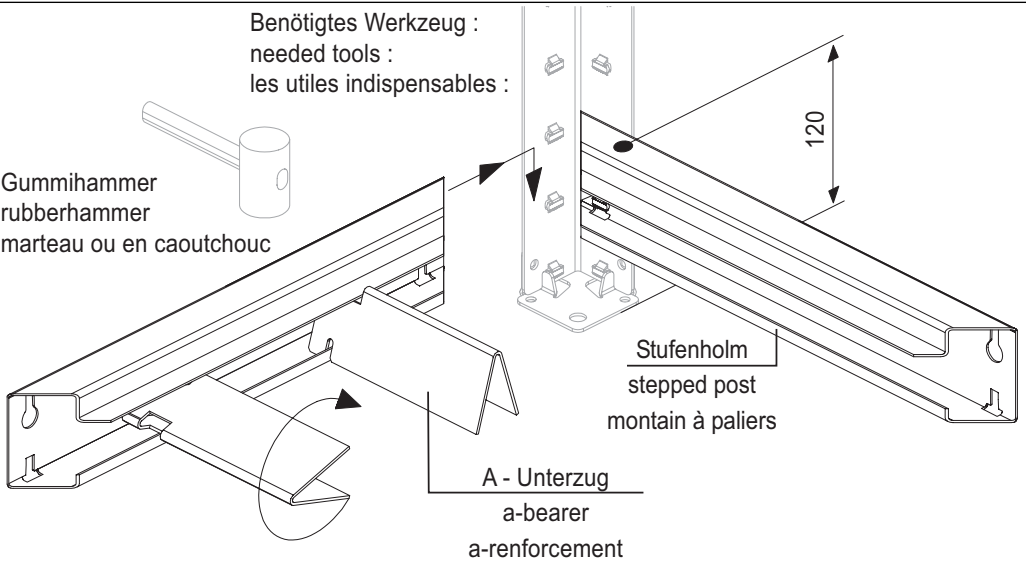
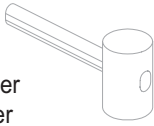

Stufenholm
stepped post
montain à paliers

A - Unterzug
a-bearer
a-renforcement

8 mm

Profilklammer als Zubehör erhältlich .
Profile clamps available as accessories.
Bride de profil disponible en tant qu'accessoire.

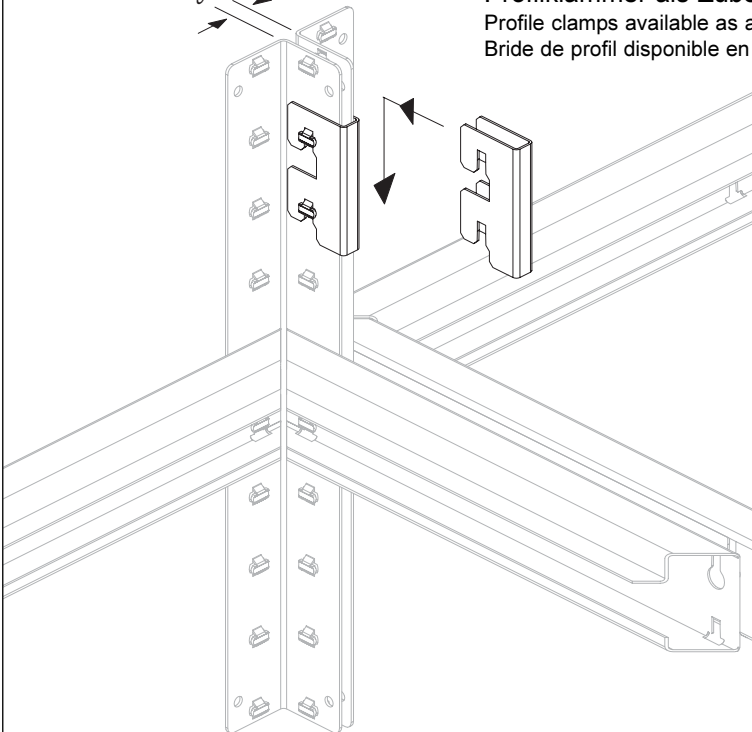

Fach- und Feldbelastungen
 compartment- and bay capacities / capacités de case - travée

B	f	F	h max.
1700 mm 2000 mm	500 kg	1500 kg	1450 mm
		2000 kg	950 mm
		2500 kg	750 mm
		3000 kg	600 mm
2500 mm	400 kg	1200 kg	1450 mm
		1600 kg	950 mm
		2000 kg	750 mm
		2400 kg	600 mm
		2800 kg	500 mm
	gleichmässig verteilte Last evenly distributed load charges uniformément		

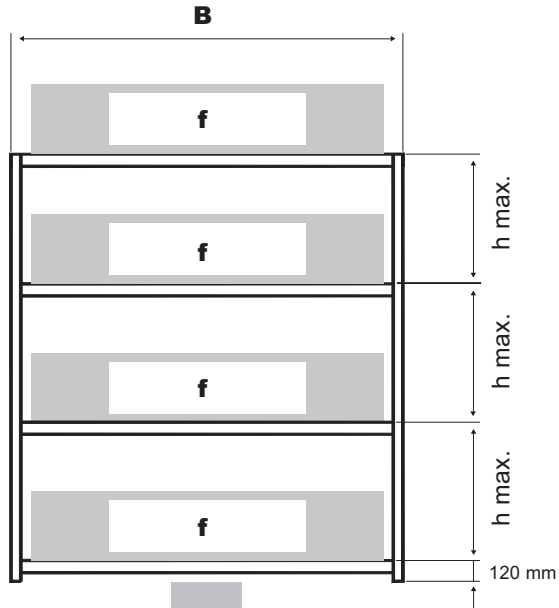

$$F = f+f+f+f$$